

## Instrumentation/accessories for pneumatic valves

- option
- standard

Other options and combinations of several accessories are possible, please enquire.

Optical position indicators	<b>Optical position indicator</b> For all control functions	GEMÜ 1300
	<b>Optical position indicator</b> For mounting of proximity switches/control function "normally closed" (NC)	GEMÜ 1310
	<b>Optical position indicator</b> With stroke limiter for control function "normally open" (NO)	GEMÜ 1151 – 1161
	<b>Optical position indicator</b> With stroke limiter and manual override for control function "normally closed" (NC)	GEMÜ 1114
Stroke limiters, seal adjuster	<b>Stroke limiter with seal adjuster</b> For control function "normally open" (NO)	GEMÜ 1106
	<b>Stroke limiter</b> For control function "normally closed" (NC)	GEMÜ 1151
	<b>Stroke limiter</b> For control function "normally open" (NO)	GEMÜ 1110 – 1161
Proximity switches	<b>Proximity switches</b> mounted and adjustable	GEMÜ 1200
	<b>Mount for proximity switches</b> closed	GEMÜ 1210
	<b>Mount for proximity switches</b> open	GEMÜ 1216
Electrical position indicators	<b>Electrical position indicator</b> (indication: valve open)	GEMÜ 1215
	<b>Electrical position indicator</b> (indication: valve open and/or closed)	GEMÜ 1235
	<b>Electrical position indicator</b> (indication: valve open and/or closed)	GEMÜ 1230 – 1232
	<b>Electrical position indicator</b> (indication: valve open and/or closed)	GEMÜ 1201 – 1214
Controllers	<b>Electro-pneumatic positioner</b> For direct mounting to pneumatically operated valves	GEMÜ 1434 $\mu$ Pos
	<b>Electro-pneumatic positioner</b> For direct or remote mounting to pneumatically operated valves	GEMÜ 1435 $\epsilon$ Pos
	<b>Electro-pneumatic positioner with integrated process controller</b> For direct or remote mounting to pneumatic linear valves	GEMÜ 1436 $\epsilon$ Pos
	<b>Combi switchbox with integrated 3/2-way pilot valve</b> For direct mounting to pneumatic linear valves	GEMÜ 4222
Manual override, Pilot valves	<b>Manual override</b> With optical position indicator	GEMÜ 1002
	<b>Manual override</b> On NAMUR bracket with mounted limit switches	GEMÜ 1460
	<b>NAMUR bracket</b>	GEMÜ 1450
	<b>Pilot valves</b> for direct mounting to pneumatic valves	GEMÜ 324 and GEMÜ 334

## Electrical Position Indicator Guide

	1201*	1205*	1211*	1214*	1215	1230	1231	1232	1235	4222
Explosionproof		X								
Micro-Switch (Single Position)	X	X			X	X	X	X		
Micro-Switch (Dual Position)	X	X				X	X	X		
Proximity Sensor (Intrinsically Safe)			X				X			
Proximity Sensor				X				X		
Relay Switch									X	
Field bus connection AS-I									X	X
with integrated 3/2 way pilot valve										X
Microprocessor controlled position detection									X	
Single position indication	X	X	X	X	X	X	X	X	X	X
Dual position indication	X	X	X	X		X	X	X	X	X
<b>Actuators - Fail Closed, Fail Open &amp; Double Acting:</b>										
Type 684 - 1/2"	X	X	X	X	X	X	X	X	X	X
Type 684 - 3/4"	X	X	X	X	X	X	X	X	X	X
Type 684 - 1"	X	X	X	X	X	X	X	X	X	X
Type 684 - 1-1/2"	X	X	X	X	X	X	X	X	X	X
Type 684 - 2"	X	X	X	X	X	X	X	X	X	X
Type 620 - 2-1/2"	X	X	X	X	X	X	X	X	X	X
Type 620 - 3"	X	X	X	X	X				X	X
Type 620 - 4"	X	X	X	X	X				X	X
Type 620 - 5"	X	X	X	X	X				X	X
Type 620 - 6"	X	X	X	X	X				X	X
Type 687 1/2"	X	X	X	X	X	X	X	X	X	X
Type 687 3/4"	X	X	X	X	X	X	X	X	X	X
Type 687 1"	X	X	X	X	X	X	X	X	X	X
Type 687 1 1/2"	X	X	X	X	X	X	X	X	X	X
Type 687 2"	X	X	X	X	X	X	X	X	X	X
Type 687 3"	X	X	X	X	X	X	X	X	X	X
Type 687 4"	X	X	X	X	X	X	X	X	X	X
Type 695 1/2"	X	X	X	X	X	X	X	X	X	X
Type 695 3/4"	X	X	X	X	X	X	X	X	X	X
Type 695 1"	X	X	X	X	X	X	X	X	X	X
Type 695 1 1/2"	X	X	X	X	X	X	X	X	X	X
Type 695 2"	X	X	X	X	X	X	X	X	X	X

\* Typically used on valve sizes 2 1/2", 3", and 4"

## Type 1201 Electrical Position Indicator



**For valve types:**  
620, 684, 687, 695

With micro switches

### Contact Ratings

Voltage Volts	Resistance Amps.	Glow Lamp Duty Amps.	Inductive Duty Amps.
125 ~	10	1	10
250 ~	10	1	10
380 ~	6	-	6
15 =	15	1.5	15
30 =	8	1.5	7.5
50 =	3	0.8	2.5
75 =	1	0.6	0.5
125 =	0.5	0.5	0.07
250 =	0.25	0.25	0.03

### Wiring Diagram

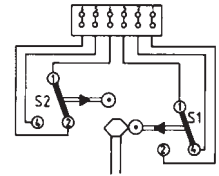

Switches S1 and S2  
Connected with terminal block

## Type 1205 Electrical Position Indicator



**For valve types:**  
620, 684, 687, 695

Explosion-proof design

### Switching performance

Voltage	Resistive load - amps
250 V a.c.	5 A
250 V d.c.	0.2 A
60 V d.c.	1 A
30 V d.c.	2 A

PTB Certificate No.. Ex-84/1119

### Circuit diagram

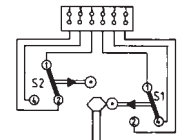

Switches S1 and S2  
connected to terminal  
block acc. to circuit  
diagram

## Type 1211 Electrical Position Indicator



**For valve types:**  
620, 684, 687, 695

With proximity switches  
according to NAMUR

### Wiring recommendation

Power supply for the control circuit

Open-circuit voltage	U.	7-9 V
Recommended voltage		8.2 V
Short circuit current	J <sub>k</sub>	7-16 mA
Recommended current		8.2 mA

### Circuit diagram

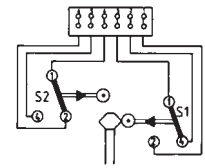

Switches S1 and S2  
connected to terminal block  
acc. to circuit diagram

## Type 1214 Electrical Position Indicator



**For valve types:**  
620, 684, 687, 695

With proximity switches and  
integral amplifier

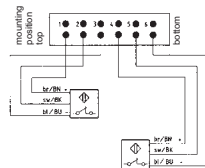

### Inductive proximity switch (BALLUFF)

	Standard types
Rated voltage	10 - 30 VDC
Tolerance range of rated operating distance	± 10%
Residual ripple	max. 15%
No-load current	10 - 20 mA
Output resistance Ra and diode	4.7 kW
Output resistance Ra and diode in BES with integrated LED	2.2 kW
Residual voltage with a load impedance of 10 kW	≤ 0.8 V
Voltage drop	0.8 V - 1.8 V
Hysteresis	≤ 15%
Edge steepness <sup>1)</sup>	≥ 1 V/μs
Output loading capability load impedance	60 mA - 400 mA
Duty cycle	100%
Ambient temperature	-13° F up to +158° F



**Type 1230**  
Electrical Position Indicator

**For valve types:**  
620, 684, 687, 695

With micro-switches

**Voltages:** 10-30 V d.c. Other voltages on request  
4 A at 24 V d.c.

**Rated working current:**  
**Power consumption of the unit itself:** 10 mA at 10 V d.c.  
35 mA at 30 V d.c.

**Protection class:** IP 65  
LED indicators only integrated in special design



**Type 1231**  
Electrical Position Indicator

**For valve types:**  
620, 684, 687, 695

with proximity switches  
Two wires according to NAMUR

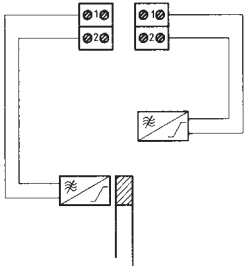

Undamped



blu -  
bk +

$\geq 4\text{mA}$

Damped



blu -  
bk +

$\leq 1\text{mA}$

**Voltages:**  $U_N$  nominal voltage 8.2 V/DC  
 $U_B$  operating voltage 7.7-9.0 V  
 $R_V$  550-1100

**Series resistance:** 2.0 kHz

**Max switching frequency:** less than 1 mA

**Intrinsic current consumption:** 4-6 mA

**damped:**

**undamped:**



**Type 1232**  
Electrical Position Indicator

**For valve types:**  
620, 684, 687, 695

with proximity switches

**Voltages:** 10-30 V d.c.

**Switch rating:** Up to 200 mA

**Output resistance:** 4.7 k Ohm

**Maximum switching frequency:** 1.5 kHz

**Standard design**  
Power consumption of the unit itself:  
Standard with 2 proximity switches  
Closed (high flux):  $\leq 40\text{ mA}$   
Open (low flux):  $\leq 24\text{ mA}$   
PNP or NPN

**Special design**  
Power consumption of the unit itself with LED (optional):  
Closed (high flux):  $\leq 90\text{ mA}$   
Open (low flux):  $\leq 50\text{ mA}$   
PNP or NPN



**Type 1235**  
Electrical Position Indicator

**For valve types:**  
620, 684, 687, 695

**Voltage supply:** 24 VDC (16-32 VDC)  
Admissible ripple  $\pm V$  (<150 Hz)

**Current consumption:** 70 mA at nominal voltage

**Power consumption Rating:** 1.7W  
100% rating

**Output Signals**  
Type of contact: 2 x closing contact, mechanical relay  
Switching voltage / contact  $\leq 36\text{ VDC} / \text{VAC}$   
Switching current / contact  $\leq 1\text{ A}$   
Switching rating / contact  $\leq 15\text{ W}$   
Number of operations typ.  $7 \cdot 10^6$  at 12 VDC, 100 mA  
typ.  $2 \cdot 10^7$  at 36 VDC, 10 mA

**Switching points (before the respective end position)**

Travel length	Ref. No. 030	Ref. No. 050
Switching Point CLOSED	6 % of stroke, min. 0.5 mm	6 % of stroke, min. 0.7 mm
Switching Point OPEN	25 % pf stroke, min. 0.5 mm	25 % pf stroke, min. 0.7 mm
Hysteresis	0.25 mm	0.35 mm
Minimum stroke	3 mm	6 mm

**Signal processing**  
Signal delay td1  $\leq 100\text{ ms}$   
Signal delay td2  $< 125\text{ ms}$   
Signal interval ta 3 ms

**Resolution (stroke)** 8 bit

**Protection type** IP 67

**Protection class** III

**Electrical connection**  
5 pole M12 concentric plug and socket connection  
Max. Contact voltage 36 VDC, 30 VAC

**Optical indication**  
LED green position OPEN  
LED yellow ready for operation POWER  
LED orange position CLOSED  
Green / orange LEDs flash alternately = programming mode

**Ambient temperature**  
Operation:  $-20^\circ\text{C}$  to  $70^\circ\text{C}$   
Storage:  $-20^\circ\text{C}$  to  $70^\circ\text{C}$

**Directives**  
EC EMC directive 89/336/EEC  
Emission of interference EN 50081-1  
Immunity to interference EN 50082-2  
EC low voltage directive 73/23/EEC

**Option for field bus connection with AS-i**  
Consult factory

### Type 1215



**Electrical Position Indicator**

**For valve types:**  
620, 684, 687, 695

With micro switches

Suitable for use at ambient temperatures of 5° F to +131° F.

Protection class: IP 65 (when mounted)

**Contact ratings:**  
AC ratings  
Voltage 250 V a.c.  
Resistance 4 A  
DC ratings Voltage 24 V d.c  
Resistance 4 A  
Inductive duty 0.6 A

**When ordering, please give the complete valve type key.**  
e.g. Type 1215 to be fitted to a valve type 690/20 D 0114-1

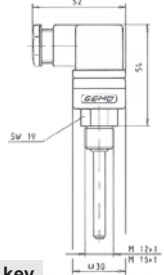

### Type 1310



**Electrical Position Indicator**

**For valve types:**  
620, 684, 687, 695

control function 1  
Manually operated

*for proximity switch adaption  
( M 18 x 1 )*

### Type 4222



**Combi switchbox with integrated 3/2 way pilot valve**

**For valve types:**  
620, 684, 687, 695

<b>Supply voltage</b>	Operating Voltage 29.5 ... 31.6 VDC	<b>AS-I Interface</b>	Reverse battery protection yes
	acc. To AS-I specification indication with green LED		AS-I configuration S 1.F
	Operation with yellow AS-I wire		E/A configuration 1
	Current consumption typ. 100 mA		ID-codes F
<b>Switching output</b>	Output wiring Port D3, PNP, yellow LED	<b>Directives</b>	AS-I certificate in preparation
	Galvanically decoupled yes		EC EMC directive 89/336/EEC
<b>Signal output potentiometer control</b>	Potentiometer function Port D2, red LED		Emission of interference EN 50081-1
	1=error		Immunity to interference EN 50082-2
<b>Connection</b>	Operation with yellow AS-I wire AS-I plug M12 e.g. GEMÜ type 4180		EC low voltage directive 73/23/EEC
<b>Signal inputs end positions</b>	<i>Valve "CLOSED" position</i>	<b>Technical specifications</b>	Medium lubricated/unlubricated air 5 µm
	Setting with potentiometer		Operating pressure 2-8 bar
	Indication for setting yellow LED, in the housing		Flow rate (at 6 bar) 140 l/min.
	AS-I input Port D1, 1=closed		Switching time < 15 ms
	<i>Valve "OPEN" position</i>		Switching frequency max. 10 Hz
	Setting with potentiometer		Protection class IP 65 (mounted to the valve)
	Indication for setting yellow LED, in the housing		Ambient temperature +5°C...+50°C
	AS-I input Port D0, 1=open		<b>Attention:</b> Note max. control pressure of valve actuator!

*LON interface available  
consult factory*

### Types 1100/1101/1103/1104



**Stroke limiter**

control function 1  
Manually operated

### Types 1110/1111



**Stroke limiter**

control function 2  
Pneumatically operated

**Type 1114** Stroke limiter



With optical position indicator and emergency manual operation facility

**Type 1300** Optical position indicator



**Type 1151/1153/1154** Stroke limiter



With optical position indicator  
Control function 1

**Type 1301** Transparent cap (sight glass)



For the type 1104  
Stroke limiter

**Type 1161/1165** Stroke limiter



With optical position indicator  
Control function 2

## Types 320-324 Solenoid valves



Pilot valves for pneumatically operated actuators. Suitable for direct mounting, single and battery mounting versions available

<b>Duty cycle:</b>	100%
<b>Max. operating frequency:</b>	3600 times/hour
<b>Switching time:</b>	20 ms
<b>Voltages:</b>	
<b>A.C. voltage:</b>	24, 42, 48, 110, 220, 240 V/50 Hz
<b>D.C. voltage:</b>	24, 110, 220 V/60 Hz
	12, 24, 48, 110 V/DC
	Other voltages and frequencies are available on request
<b>Permissible voltage tolerances:</b>	-10/+5% according to VDE 0580
<b>Weight:</b>	220 g
<b>Approvals:</b>	According to UL
<b>Power consumption:</b>	
<b>Pull in current:</b>	18 VA
<b>Hold in current:</b>	8 VA or 6,5 Watt
<b>Protection class:</b>	IP 65
<b>Electrical connection:</b>	Standard plug with PG 11 gland plug can be rotated through 90°
<b>Temperature range:</b>	-15 to + 50°C
<b>Ambient temperature:</b>	-20 to + 50°C
<b>Operating pressure:</b>	0 - 10 bar
<b>K<sub>v</sub>-Value:</b>	Normally closed: 2.0 l/min Normally open: 1.67 l/min (see diagram on page 2)
<b>Installation note:</b>	<b>If installed in switch gear cubicles adequate ventilation must be provided</b>

## Types 332/334 Solenoid valves

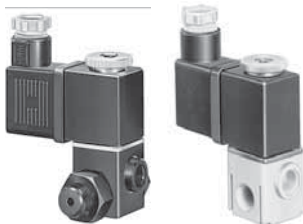

Pilot valves for pneumatically operated actuators. Suitable for direct mounting, single and battery mounting versions available

<b>Medium:</b>	Inert gases
<b>Cycles:</b>	3600 per hour
<b>Switching time:</b>	20 ms
<b>Voltage:</b>	
<b>AC Voltage:</b>	220 V/50 Hz, other voltages and frequencies available upon request
<b>Permissible voltage tolerances:</b>	-10/ +5% per VDE 0580
<b>Weight:</b>	100g
<b>Size:</b>	1 mm
<b>K<sub>v</sub>-value:</b>	0.05 m <sup>3</sup> /h
<b>Body configuration:</b>	Multi-port (M)
<b>Pull in current:</b>	6.5 VA
<b>Hold in current:</b>	4.8 Watts
<b>Protection class:</b>	IP 65
<b>Electrical connection:</b>	Standard plug with PG 9 gland, plug rotatable through 180°
<b>Temperature range:</b>	-15° C to + 20° C
<b>Ambient temperature:</b>	-20° C to + 50° C
<b>Operating pressure:</b>	0-10 bar
<b>Installation note:</b>	if installed in switch gear cubicles adequate ventilation must be provided.

## Types 1410/1411/1413 Pneumatic positioner



**For valve types:**  
620, 684, 687, 695

**Input Range**  
3-15 psi, 0.2-1 bar  
Up to 4 wa split ranging (3 psi input) is possible

**Output Range**  
0 to 100% of supply pressure

**Supply Pressure**  
20 to 150 psi<sup>1</sup> (1.4 to 10 bars)

**Approximate Mass**  
Single-acting: 1.4 lb (0.65 kg)  
Double-acting: 1.7 lb (0.75 kg)

## Types 1420/1423 Electro-pneumatic positioner

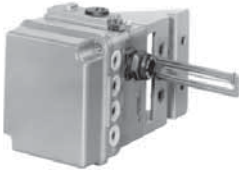

**For valve types:**  
620, 684, 687, 695

**Input Range**  
0 to 20 mA (up to 4-way split range is possible)  
4 to 20 mA (up to 3-way split range is possible)

**Output Range**  
0 - 100% of supply pressure

**Supply Pressure**  
20 to 150 psi (1.4 to 10 bars)<sub>1</sub>

**Input Resistance**  
< 200 Ω at 68°F (20°C)

**Approximate Mass**  
Single-acting: 3.3 lb (1.5 kg)  
Double-acting: 4 lb (1.8 kg)

## Types 1435 ePOS Intelligent Positioner



**For valve types:**  
620, 684, 687, 695

### General specifications

Protection class acc. To EN 60529 IP 65  
Dimensions L x W x H 160 x 90 x 84 mm  
Weight 1.6 kg  
Mounting position optional  
EC EMC directive 89/336/EEC  
EC low voltage directive 73/23/EEC  
Emission of interference EN 50081-2  
Immunity to interference EN 50082-2  
Characteristic feature During power or pneumatic supply failure the valve adopts a safe position

### Electrical specifications

**Supply voltage** 24 VDC ± 10%  
**Supply voltage** ≤ 7.2 W (during operation)  
**Power consumption** ≤ 2.4 W (while idle)  
**Characteristic accuracy** ≤ 1%

### Input / output signals

**Input signals** a) 0-10 V; b) 0/4...20 mA  
**Input resistance** a) 200 K Ω; B) 250 Ω  
**Position indication** 0-10 v; 4...20 mA (optional)  
**Binary outputs** 2 alarm outputs  
1 error message output

### Electrical connection

**Supply voltage** M16 Cable entry  
**Input signal** M16 Cable entry  
**Travel sensor** M12 Cable entry

### Operating conditions

**Ambient temperature** 0...60°C  
**Storage temperature** 0...60°C  
**Control medium** Air or inert gasses, filtered 50 μm, lubricated or unlubricated

**Additional air** 0-6 bar  
**Air output** 50, 90 NI/min; depending on type (P<sub>2</sub>=6 bar)

**Air consumption (when idle)** 0 NI/min

### Functional specifications

**Control function** • Normally closed  
• Normally open  
• Double acting  
**Operation** • Automatic calibration  
• Automatic  
• Manual  
**Parameter** Adjustable

### Materials

**Housing** Aluminum, Epoxy coated  
**Display cover** PMMA  
**Key cover** PMMA  
**Travel sensor** Anod. Alu } linear version  
PEEK }  
PAI } quarter turn version  
NBR }

### Travel sensor

**Linear Version**  
**Mounting** External  
**Stroke** 0-30, 0-50, 0-75 mm  
**Connection** Pre-fitted cable

### Quarter turn version

**Mounting** External  
**Angle of turn** 0-100°  
**Connection** Pre-fitted cable



### Action

**Single acting** Ref. no. 1  
**Double acting** Ref. no. 3

**Explosion-proof class** Ref. no. Without explosion-proof rating 0

**Accessories mounted** Ref. no. Without 0  
**Position indication** 4-20 mA 2  
Further accessories upon request

**Flow rate** Ref. no. Q = 50 l/min 01  
Q = 90 l/min (only single acting) 02

<p><b>Type 1450</b> Mounting bracket complying with NAMUR</p>  <p><b>For valve types:</b> 620, 684, 687, 695</p>	<p><b>Type 1002</b> Manual Override</p>  <p><b>For valve types:</b> 620, 684, 687, 695</p>
---	--

**Types 1281/1284** 3-point controller



*For panel mounting or direct attachment*

**Type 1281**  
For panel mounting or direct mounting on the valve

**Type 1284**  
For panel mounting or direct mounting on the valve with additional LED indication (light column)

**Types 1286/1289** 3-point controller



*Euro-card for 19" or 24" racks with 31 pole terminal strip complying with DIN 41617*

**Type 1286**  
Eurocard for 19/24" rack with 31 pole terminal strip complying with DIN 41617

**Type 1289**  
Eurocard for 19/24" rack with 31 pole terminal strip complying with DIN 41617 and additional LED indication (light column)